

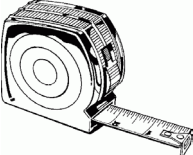

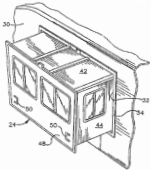

BAL NXGII Frame Design Request

Customer:	Model Name/Number:	Plant:
Date of Request:	Contact Email:	Online Date:
Requested by:	Phone:	

New Model Line	New Model to existing line	Revision to Existing Frame	Print Blank Form
Travel Trailer	Fifth Wheel	Park Model	Toy Hauler

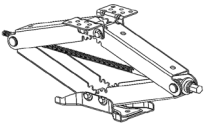
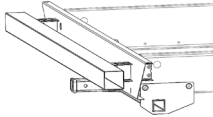
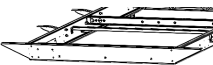
Capacity & Coupling		GVWR	Hitch Weight	Ball Size	Construction							
				2" 2-5/16"	Floor:	Laminated	Stick/Tube	Thickness:				
		Coupler Type:			Walls:	Laminated	Stick and Tin					
		Safety Chains:			UnderBelly:	Below Flange	Above Flange	None				
Dimensions		Length (L)	Width (W_o)									
		Width (W_i)										
		59.15 / 59.39		64.15 / 64.39								
		68.15 / 68.39		74.15 / 74.39								
		Unknown		Other:								
Ball Center/ Upper Deck Length (B)												
Under Slung		Pass Through										
Slide Outs		Type	Description	Weight	Width	Travel	Start	End	RS/CS	Above/Flush	Room Bar	
		1										
		2										
		3										
		4										
Axle		Type:		Torsion		Sprung						
		Axle Capacity:		Number of Axles:		Axle Manufacturer:						
		Hub Face:		Axle Spacing:		Axle Product Name/Size:						
Leveling & Stabilization		BAL Auto Leveling & Stabilization				Manual Stabilization						
		7.3 Leveling				Component	Manufacturer					
		5.3 Leveling				Power C-Jacks						
		4.4 & 6.6 Leveling (FW)				Manual C-Jacks						
		5.1 Stabilization				Scissor Jacks						
Bumper & Hitch		Bumper		Rear Close-Out		Accessory Hitch			Gear Rack			
		Extension from Frame						1-1/4" (150 lb capacity)				
		Capacity						2" (250 lb capacity)				
		Under Slung						Towing				
Extras		Spare Tire Carrier	Skid Bars	Under Belly Brackets	Suspension							
												
		A-Frame In-Frame Bottom Mount Bumper Mount			Direct Frame Mount Torsion Axle Mount							
Comments												

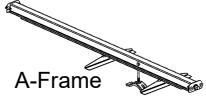
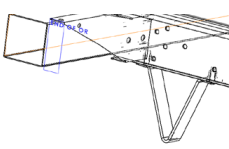
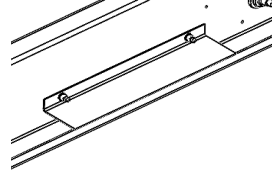
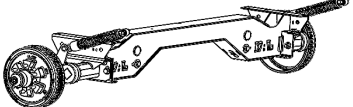
Attached Information

Prints

CAD Data

Emails

Other

Email Frame Design Requests to: NorcoBalEng@norcoind.com

J Stough

8/9/2023

FOR-0095 Rev G