

<b>CABLE SLIDE STANDOFF BRACKETS</b>	<b>BRAND:</b> BAL ACCU SLIDE	<b>CREATED DATE:</b> 06/14/2024
<b>ID NUMBER:</b> SQS.ACCU.003	<b>TYPE:</b> All ACCU Slides	<b>REVISION:</b>

Standoff Brackets should initially be installed with three (3) screws. Installing a fastener in each slotted hole and one round hole, allows for vertical adjustment. *All six (6) holes should have a fastener after the bracket position is adjusted properly.*

**Step 1: Obtain Measurements**

Measure from the top of the glide surface [peak of wear bar or roller] up to the center of the exit hole of the cable by pulling the cable straight out for both the bottom and top cables.



WEAR BAR

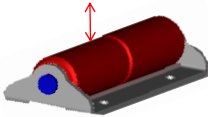

ROLLER

JAMB

EXIT HOLE

EXIT HOLE

Measurement 2

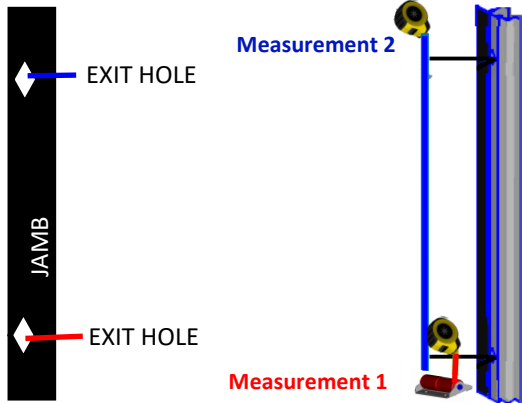

Measurement 1

**Step 2: Install Exterior Standoff Brackets**

Apply the measurements to the slide end walls, by measuring from the bottom edge of the slide room box.

**Fasteners:** #10 to #12 flat, button or pan

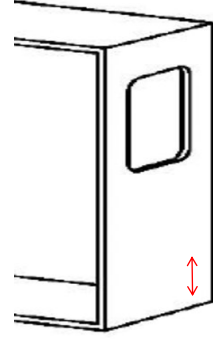

APPLY MEASUREMENT 1

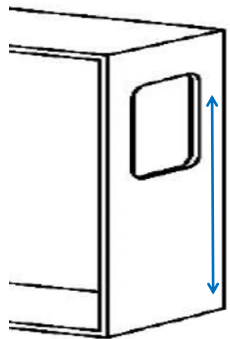



APPLY MEASUREMENT 2

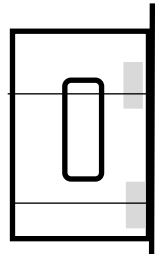

⚠ Self tapping screws may be used to install the exterior standoff brackets through the leg of the t-mold.

⚠ An additional #10 screw should be fastened through the face of the t-mold for each bracket.

**Step 3: Install Interior Standoff Brackets**

**STRAIGHT IN AND OUT [NON-FLUSH FLOOR]**

Apply the measurements to the slide end walls, by measuring from the bottom exterior edge of the slide room end wall.

**Fasteners:** #10 to #12 flat, button or pan

⚠ **Do not use self tapping screws to install in the interior standoff brackets**

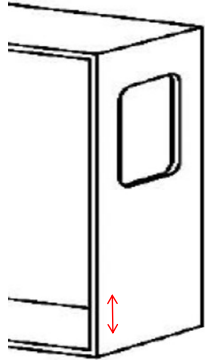

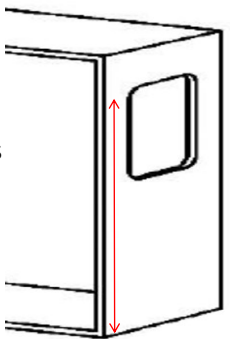

INTERIOR BRACKETS





<b>CABLE SLIDE STANDOFF BRACKETS</b>	<b>BRAND:</b> BAL ACCU SLIDE	<b>CREATED DATE:</b> 06/14/2024
--------------------------------------	------------------------------	---------------------------------

<b>ID NUMBER:</b> SQS.ACCU.003	<b>TYPE:</b> Accu Slide Flush Floor	<b>REVISION:</b>
--------------------------------	-------------------------------------	------------------

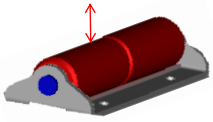
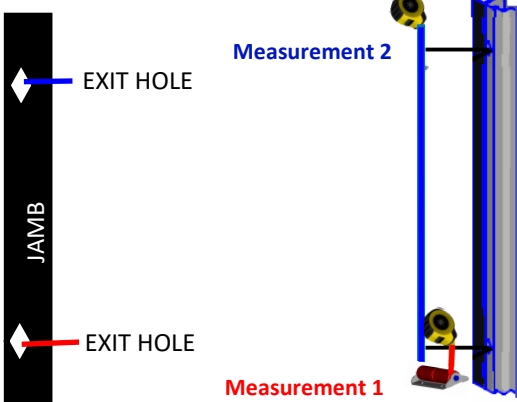
<b>Flush Floor</b>	<b>Outrigger Placement</b>	Flush Floor pans require outriggers at each end. Ensure that the outriggers do not exceed the depth of the pan.	
--------------------	----------------------------	---	---

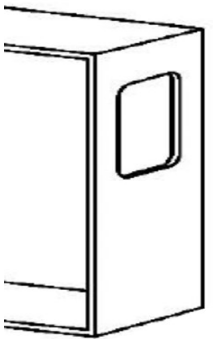
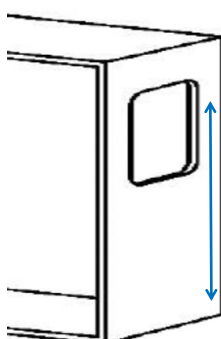
<b>Step 1: Obtain Measurements</b>	<p>Measure from the top of the glide surface [peak of wear bar or roller] up to the center of the exit hole of the cable by pulling the cable straight out for both the bottom and top cables.</p> <div style="display: flex; justify-content: space-around; align-items: center;"> <div style="text-align: center;">  <p>WEAR BAR</p> </div> <div style="text-align: center;">  <p>ROLLER</p> </div> </div>	 <p>EXIT HOLE</p> <p>JAMB</p> <p>EXIT HOLE</p> <p>Measurement 1</p> <p>Measurement 2</p>
------------------------------------	--	---

<b>Step 2: Install Exterior Standoff Brackets</b>	<p>Apply the measurements to the slide end walls, by measuring from the bottom edge of the slide room box.</p> <p><b>Fasteners:</b> #10 to #12 flat, button or pan</p>	 <p>APPLY MEASUREMENT 1</p>  <p>APPLY MEASUREMENT 2</p>
---	--	---

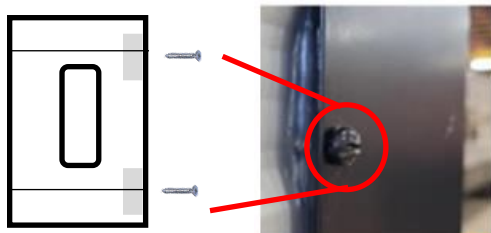
	<ul style="list-style-type: none"> <li>⚠ Self tapping screws may be used to install the exterior standoff brackets through the leg of the t-mold.</li> <li>⚠ An additional #10 screw should be fastened through the face of the t-mold for each bracket.</li> </ul>	
---	---	---

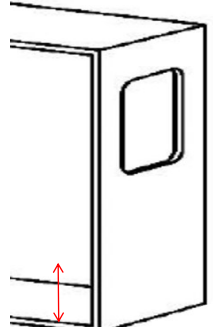
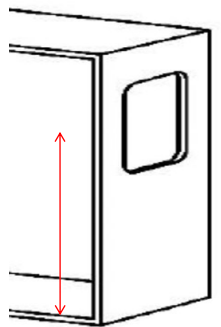
<b>Step 3: Install Interior Standoff Brackets</b>	<p><b>FLUSH FLOOR ONLY:</b></p> <p>Apply the measurements to the slide end walls, by measuring from the top surface of the slide room floor.</p> <p><b>Fasteners:</b> #10 to #12 flat, button or pan</p> <ul style="list-style-type: none"> <li>⚠ Do not use self tapping screws to install in the interior standoff brackets</li> </ul>	 
---	--	---