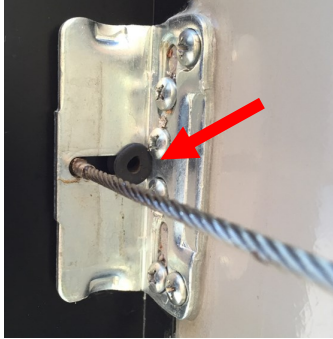
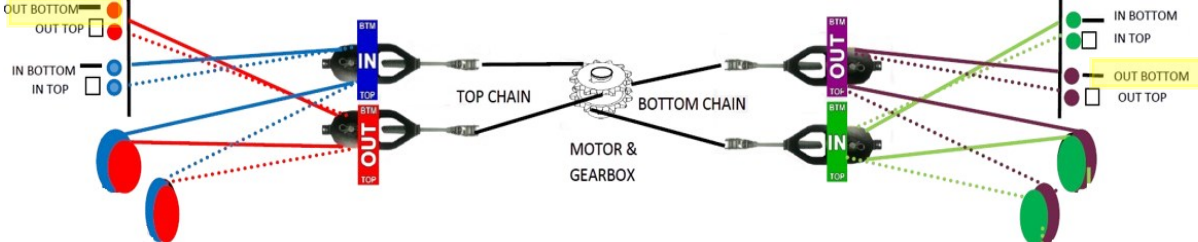
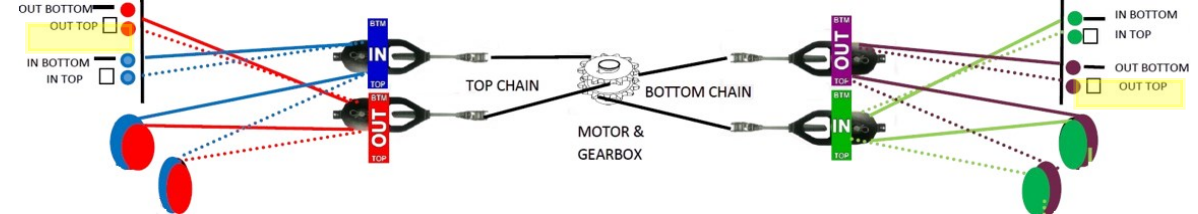
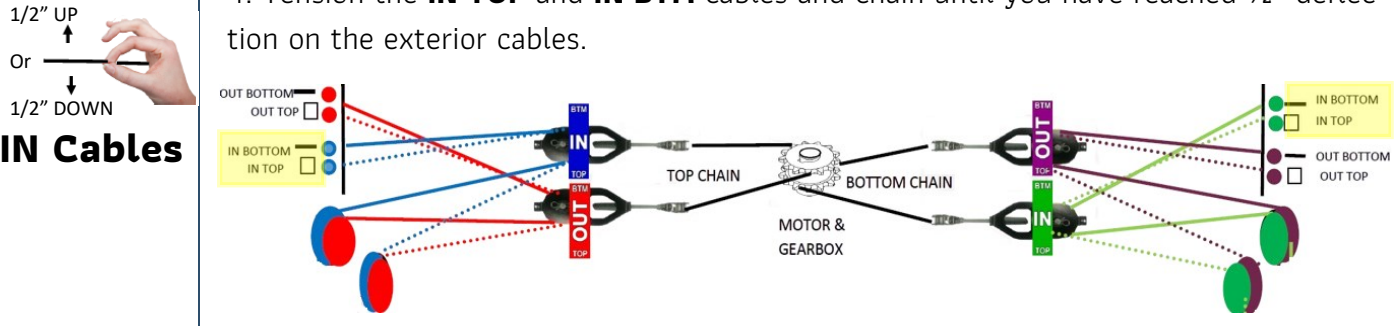

CABLE SLIDE CABLE ATTACHMENT & TENSIONING	BRAND: ACCU SLIDE	CREATED DATE: 07/11/2024
ID NUMBER: SQS.ACU.007dbl	TYPE: DOUBLE BACK	REVISION:

Step 1:		<p>Attach all 8 cables to each standoff bracket.</p> <p>Tools:</p> <ul style="list-style-type: none"> ⇒ 3/8" Gear Wrench ⇒ 7/16" Gear Wrench ⇒ Needle-nose Pliers <p>1. Extend the room.</p>	<p>Place a rubber grommet into the slotted hole of the standoff.</p> 
----------------	---	---	--

Step 2:	OUT BTM Cables	<p>2. Tension the OUT BTM cables until the bottom interior standoff brackets make contact with jamb.</p> 
----------------	-----------------------	---

Step 3:	OUT TOP Cables	<p>3. Tension the OUT TOP cables until the adjustment bracket is sitting straight up and down insuring that both OUTTOP and OUT BTM cables are tensioned evenly.</p> 
----------------	-----------------------	--

Step 4:	IN Cables	<p>4. Tension the IN TOP and IN BTM cables and chain until you have reached 1/2" deflection on the exterior cables.</p> 
----------------	------------------	--

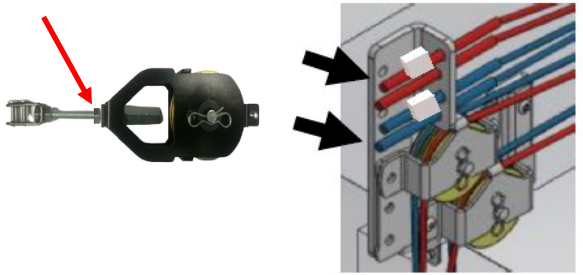
Step 5:	Chain Nut and Foam Blocks	<p>5. Tighten each chain nut against the adjustment block.</p> <p>6. Install anti-vibration blocks over every other coupler nut.</p> 
----------------	----------------------------------	--