

ELECTRICAL AND SWITCH WIRING	BRAND: BAL EXACT SLIDE G5.5	CREATED DATE: 08/23/2024
ID NUMBER: SQS.EXT.000	TYPE: Exact Slide	Revision:

- CONTROLLER**
- SUPPLY**
- BREAKER**
- GROUND**
- WIRE**

Store controller in a dry and accessible location.

Independent 12v DC supply

30 AMP Dedicated Reset Breaker (TYPE 2 OR TYPE 3)

Ground to same lug as battery **OR** Ground to BUS BAR

10 gauge wire (UP TO 65' OF DEDICATED WIRING)

8 gauge wire (65 FT+ OF DEDICATED WIRING)



The distance the current must travel from the battery to the controller dictates the AWG wire size to be used. Should the wire be too small for the distance, a voltage drop will result.

OPT 1:

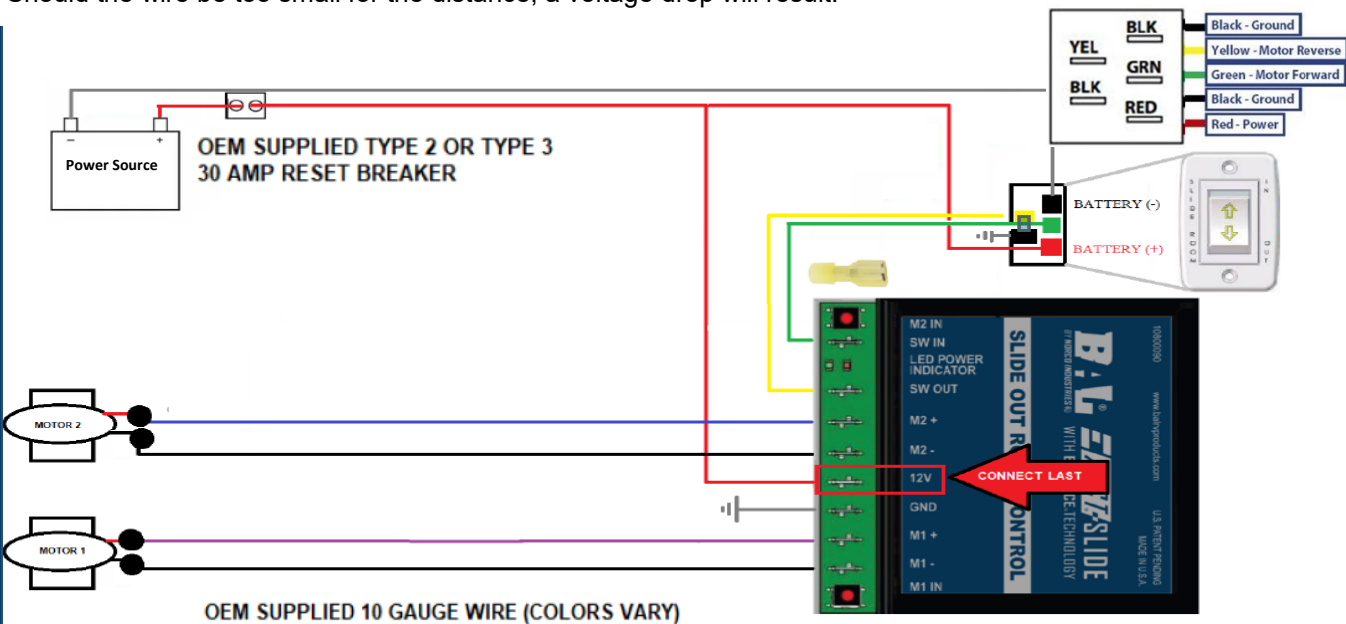

OPT 2:

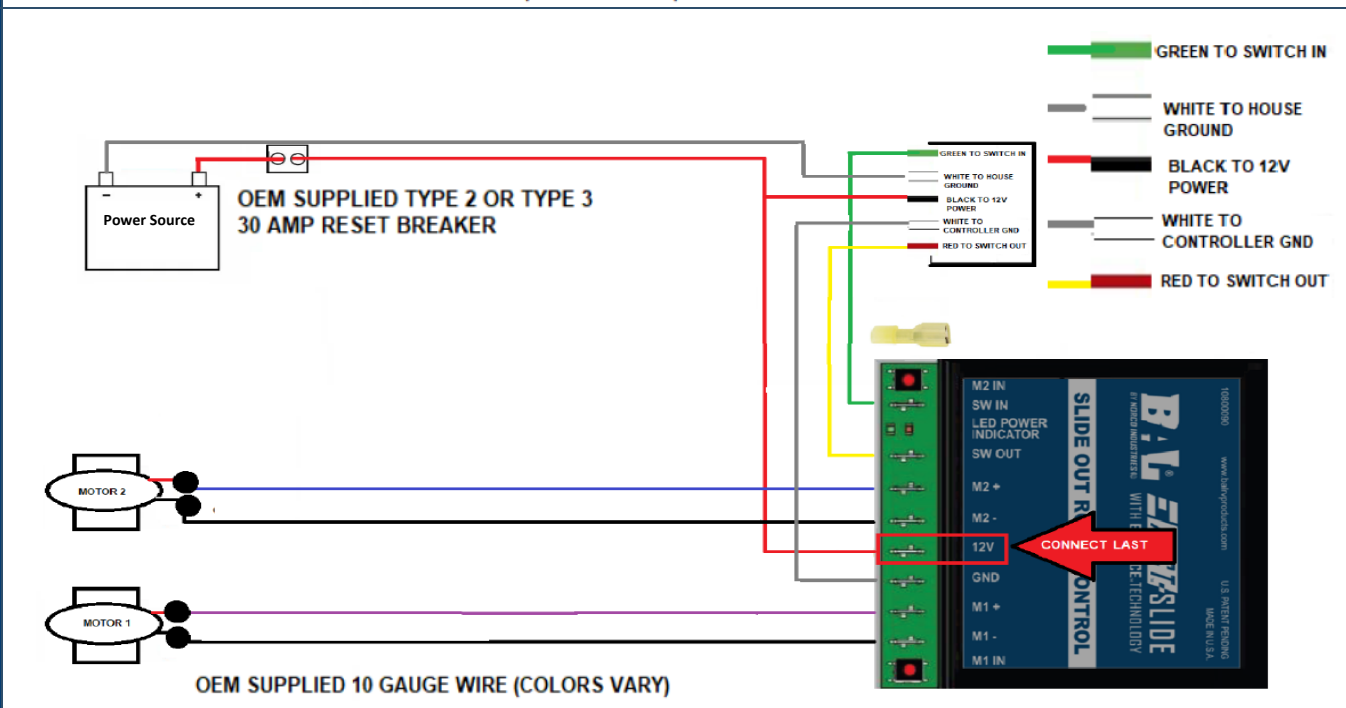

ELECTRICAL GUIDE	BRAND: BAL EXACT SLIDE G5.5	CREATED DATE: 08/23/2024
ID NUMBER: SQS.EXT.000	TYPE: Exact Slide	Revision:

OPT 3:

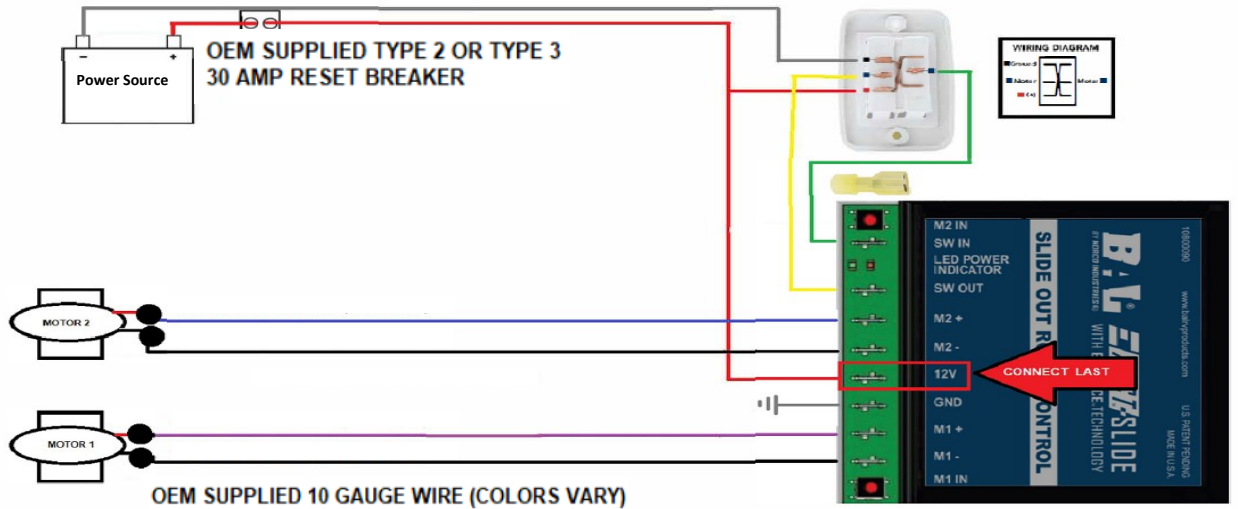

OPT 4:

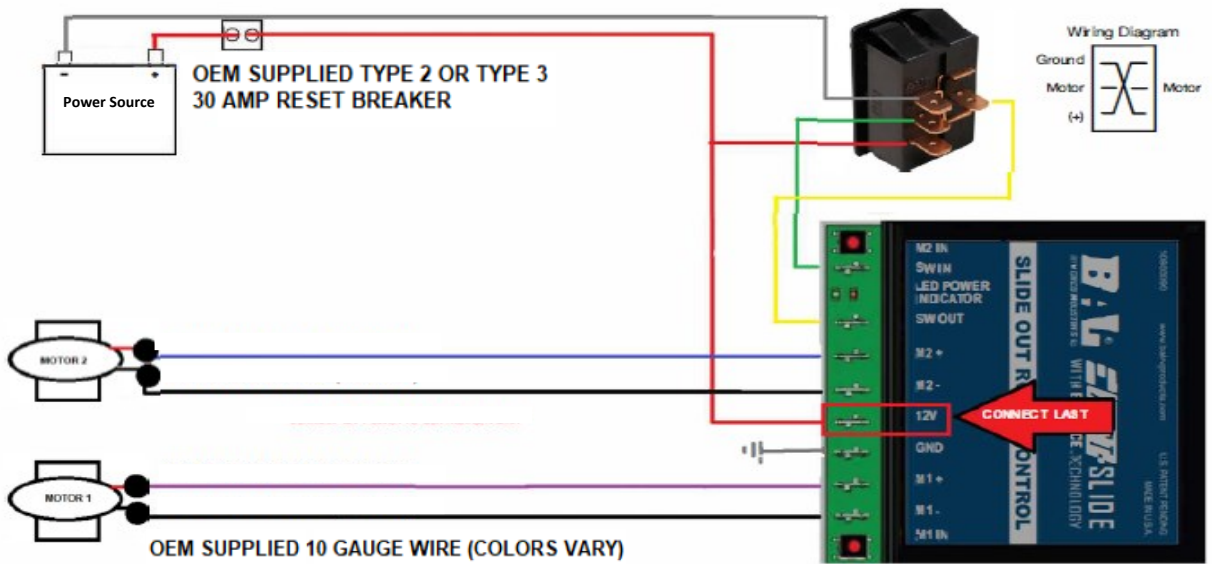

OPT 5:

